



**1-800-779-2102**

Mon – Thurs: 8:00am - 5:00pm | Friday: 8:00am - 4:00pm CST

**INSPECT YOUR PRODUCT FOR DAMAGE & MISSING PARTS BEFORE PROCEEDING TO INSTALLATION**

**PROCEDURE FOR RETURNS OR MISSING HARDWARE**

-PLEASE CONTACT THE ORIGINAL POINT OF PURCHASE FOR:  
SHIPPING DAMAGE, RETURNS, OR WARRANTY CLAIMS

-CONTACT DEE ZEE DIRECTLY FOR MISSING PARTS OR HARDWARE

**WWW.DEEZEE.COM**

REGISTER YOUR PRODUCT ONLINE: [www.deezee.com/registration](http://www.deezee.com/registration)

VIEW INSTRUCTIONS ONLINE: [www.deezee.com/instructions](http://www.deezee.com/instructions)

---

**⚠ WARNING:** Cancer and Reproductive Harm  
[www.P65Warnings.ca.gov](http://www.P65Warnings.ca.gov)

Operating, servicing, and maintaining a passenger vehicle can expose you to chemicals such as lead, phthalates, engine exhaust, and carbon monoxide that are known to the State of California cause cancer and birth defects or other reproductive harm. To minimize exposure, service your vehicle and its accessories in a well-vented area and wear gloves or wash your hands frequently.



## DEE ZEE, INC. WARRANTY AGREEMENT

Dee Zee, Inc. guarantees the original purchaser a limited lifetime warranty against manufacturer defects in materials, workmanship, and design under normal use, excluding damage resulting from road hazards such as gravel or other debris, product misuse, improper installation, impairments from accidents, product modifications, improper repairs, spills, vandalism, product neglect, or acts of God.

This warranty applies only to the original purchaser of new product(s) and is limited to the replacement of genuine Dee Zee products. Modification of any kind to Dee Zee products voids all warranty coverage. Warranty does not include electrical components, installation, cost of removal, labor, transportation costs, loss of use, inconvenience, or consequential damages.

### WARRANTY COVERAGE - MATERIALS & WORKMANSHIP

#### LIMITED LIFETIME WARRANTY:

- STAINLESS STEEL: Side Steps, Grill Guards, Bull Bars, Bed Caps, and Side Rails
- ALUMINUM: Side Steps, Running Boards, Storage Boxes, Transfer Tanks, Bed Protection, Side Rails, Invis-A-Racks, and Cab Racks
- PLASTIC: Storage Boxes
- OTHER: Front and Rear Bumpers

#### THREE-YEAR WARRANTY:

- POWDER-COATED / E-COATED STEEL: Side Steps, Running Boards, Storage Boxes, Transfer Tanks, Cab Racks, Sport Bar Ladder Racks, Cargo Carriers, Mounting Brackets (NX, Rough Step, and Bumper Guards only)
- OTHER: Tailgate Assist, Bed Mats, Floor Mats, Auxiliary Fuel Connection Kits, and All Products Not Otherwise Listed Individually

### WARRANTY COVERAGE – FINISH PROTECTION

The finish of all Dee Zee products is covered for one-year (1) from the date of purchase. Dee Zee products have a high quality finish that must be cared for and maintained like any other exposed finish on the vehicle. Protect the finish with non-abrasive automotive wax (e.g. Pure Carnauba) on a regular basis. Applying soaps, polishes, or waxes that contain an abrasive compound may scratch the finish and leave the exposed material susceptible to corrosion.

### WARRANTY COVERAGE – COMPONENT PARTS

Operational items such as shocks, latches, hinges, and wear items including, but not limited to, mud flaps, step pads, toolbox tray, end caps, hardware, seals, etc. have a one-year (1) warranty. Replacement component parts can be ordered via credit card (MasterCard or VISA) by calling 1-800-779-2102. All replacement parts are non-returnable and non-refundable.

## **GPI® FUEL PUMPS & ACCESSORIES**

All Great Plains Industries (GPI) products, including transfer tank pumps and fuel meters are covered by GPI's warranty policies. Dee Zee's warranty terms do not apply to GPI products. To submit a warranty claim, please contact GPI at 1-800-835-0113 or visit [www.gpi.net](http://www.gpi.net).

### **WARRANTY SUBMISSION PROCEDURE**

All warranty claims will be initiated at the place of purchase. The original purchaser will be required to present the original sales receipt with purchase date shown and provide photographs of the defect.

In the event the originally purchased product style is no longer available, Dee Zee will warranty the defective part with a current equivalent. If a comparable product is no longer available, the product would be returned to the store of purchase for a refund or the applicable cost difference can be paid to choose an alternate style.

### **DISCLAIMER**

All products are sold as appearance accessories and should not be relied upon as protection for the vehicle or its occupants in the event of an accident. Vehicles equipped with a supplemental restraints system (air bags) deployed by impact and collision avoidance systems should not be modified in any way. Always consult the vehicle manufacturer if you have any questions regarding supplemental restraint systems and sensors.

Buyer must accommodate front and rear sensors during product installation and assumes all risk should these be tampered, rerouted, severed, or disconnected. This includes disabling visual, audio, or vibration alerts into the cab. Buyer assumes all risk and responsibility for wiring any supplemental auxiliary lights.

Buyer assumes all risk, liability, and cost for the installation and use of Dee Zee products. Dee Zee, Inc. assumes no liability for injury, loss, incidental or consequential damages in the event of an accident.



Thank you for choosing Dee Zee to add function and accessorize your vehicle. Dee Zee has been a staple brand in the truck accessory market since 1977 and we hold a reputation of quality manufacturing based in America's Heartland. Our products are born through careful engineering and backed by industry leading warranty programs. We appreciate the opportunity to serve you and your vehicle!

**Review the instruction pages in their entirety to prepare the required tools**

**Warning:** Dee Zee Transfer Tanks are NOT to be used to transport flammable liquids such as gasoline. This tank is manufactured for private use only and does NOT meet title 49 of the United States Federal Register governing transportation.

Please check for wiring or other obstructions before drilling any holes in the vehicle. If it is necessary to drill any holes, Dee Zee recommends putting a sealant or rust inhibitory around all holes drilled into the body of the vehicle.

**Warning:** Before filling the transfer tank with fluid, visually inspect all exterior surfaces for damage. If damage has occurred, do NOT use the tank unless it is first tested for breaches with a harmless fluid such as water.

**Threaded Bung:** The transfer tank must be vented at all times for expansion and prevent vacuum formation during liquid removal or pumping. Coat threads with an acceptable thread sealing compound such as LA-CO Slic-tite Paste with Teflon. Screw threaded portion to prevent fill cap assembly into desired flange. Install the prevent cap on threaded casting, press down, and turn clockwise past the intermediate stop to the last stop. To remove the cap, turn it slowly counter-clockwise to the intermediate stop. After all pressure is relieved, push down and turn counter-clockwise and lift to remove.

**Aluminum:** When adding a steel pump to an aluminum tank, make sure the threads on the pump are clean and undamaged. Since aluminum is softer than steel, the pump will strip the threads in the tank if it's not installed with caution.

**Steel:** It is recommended to keep steel transfer tanks half full with liquid at all times. The fluid keeps the interior surface lubricated to help reduce internal corrosion risks.



Dee Zee Cares - Please Recycle

For an electronic version of these instructions visit: [www.deezee.com/instructions](http://www.deezee.com/instructions)

Register your product online: [www.deezee.com/registration](http://www.deezee.com/registration)

**Cleaning:** To be entitled to all warranty rights offered with the product, Dee Zee liquid transfer tanks need to be cleaned regularly with a mild detergent. Do NOT use abrasive cleaners.

To view available accessories, diesel fuel pumps and meters visit: [www.deezee.com](http://www.deezee.com).



Dee Zee Cares - Please Recycle

For an electronic version of these instructions visit: [www.deezee.com/instructions](http://www.deezee.com/instructions)

Register your product online: [www.deezee.com/registration](http://www.deezee.com/registration)



Thank you for choosing Dee Zee to add function and accessorize your vehicle. Dee Zee has been a staple brand in the truck accessory market since 1977 and we hold a reputation of quality manufacturing based in America's Heartland. Our products are born through careful engineering and backed by industry leading warranty programs. We appreciate the opportunity to serve you and your vehicle!

**Review the instruction pages in their entirety to prepare the required tools**

**Warning:** Dee Zee Transfer Tanks are NOT to be used to transport flammable liquids such as gasoline. This tank is manufactured for private use only and does NOT meet title 49 of the United States Federal Register governing transportation.

Please check for wiring or other obstructions before drilling any holes in the vehicle. If it is necessary to drill any holes, Dee Zee recommends putting a sealant or rust inhibitory around all holes drilled into the body of the vehicle.

**Warning:** Before filling the transfer tank with fluid, visually inspect all exterior surfaces for damage. If damage has occurred, do NOT use the tank unless it is first tested for breaches with a harmless fluid such as water.

**Threaded Bung:** The transfer tank must be vented at all times for expansion and prevent vacuum formation during liquid removal or pumping. Coat threads with an acceptable thread sealing compound such as LA-CO Slic-tite Paste with Teflon. Screw threaded portion to prevent fill cap assembly into desired flange. Install the prevent cap on threaded casting, press down, and turn clockwise past the intermediate stop to the last stop. To remove the cap, turn it slowly counter-clockwise to the intermediate stop. After all pressure is relieved, push down and turn counter-clockwise and lift to remove.

**Aluminum:** When adding a steel pump to an aluminum tank, make sure the threads on the pump are clean and undamaged. Since aluminum is softer than steel, the pump will strip the threads in the tank if it's not installed with caution.

**Steel:** It is recommended to keep steel transfer tanks half full with liquid at all times. The fluid keeps the interior surface lubricated to help reduce internal corrosion risks.

**Cleaning:** To be entitled to all warranty rights offered with the product, Dee Zee liquid transfer tanks need to be cleaned regularly with a mild detergent. Do NOT use abrasive cleaners.

To view available accessories, diesel fuel pumps and meters visit: [www.deezee.com](http://www.deezee.com).

# Combo Tank Installation Instructions

## DZ 92647(B), DZ 92647S(B), DZ 92656(B), DZ 92656S(B)

**A** Combo Tank

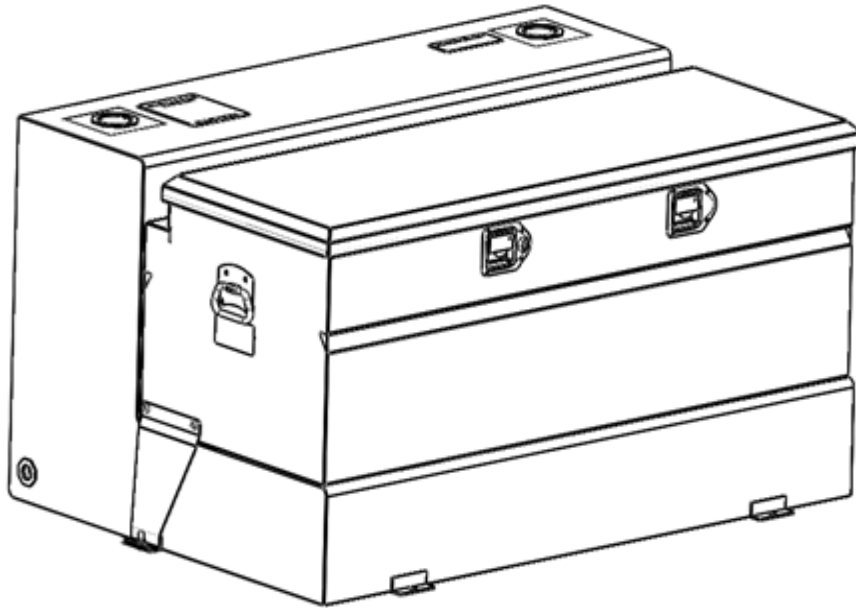

Varies

X1

**B** 5/16" Bolt

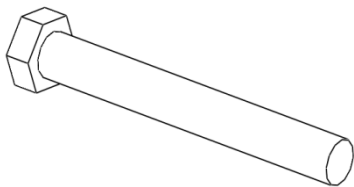

PN 1156

X4

**C** 5/16" Washer

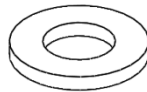

PN 339

X8

**D** 5/16" Lock Nut

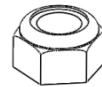

PN 240

X4

**E** Rubber Bumper



PN 1165

X4

**Tools Required:**

MARKER

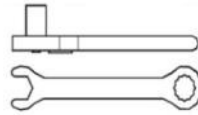

7/16"  
1/2"

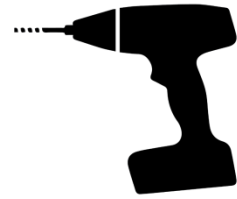

3/8"

- 1** Using a 7/16" wrench/socket, remove the bolts attaching the chest box to the tank. Remove the chest and set it aside.

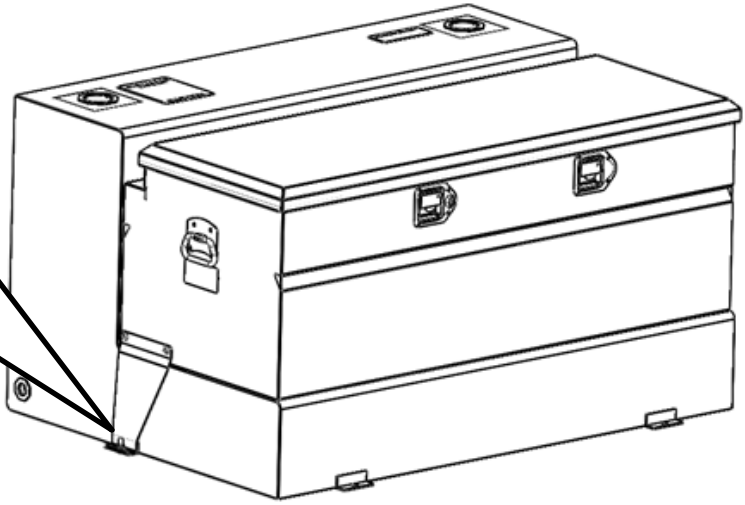
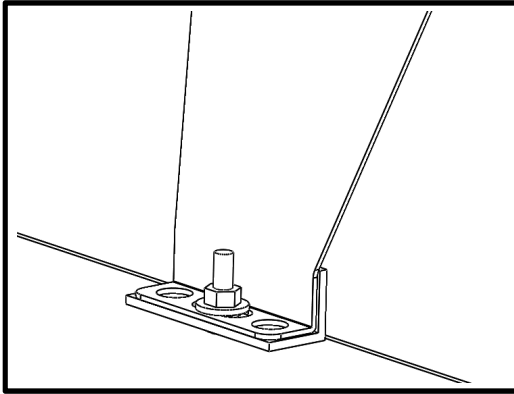

- 2** Place the tank in the truck bed.

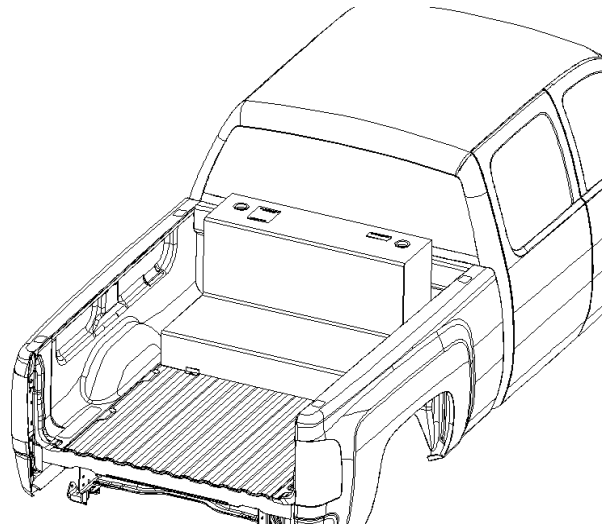
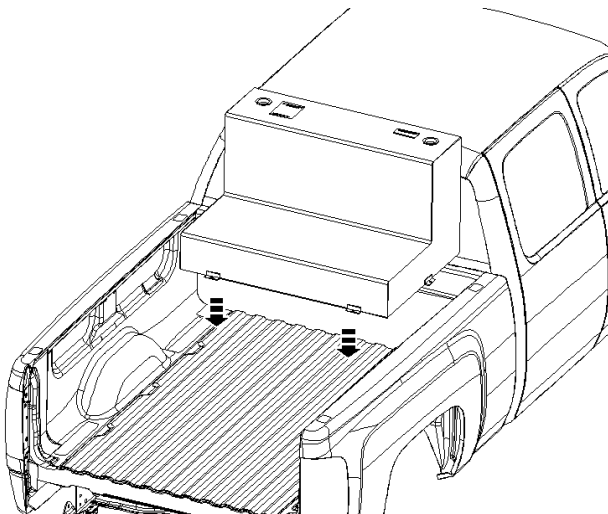



**3** Using a marker, mark the hole location in the four tank attachment points.

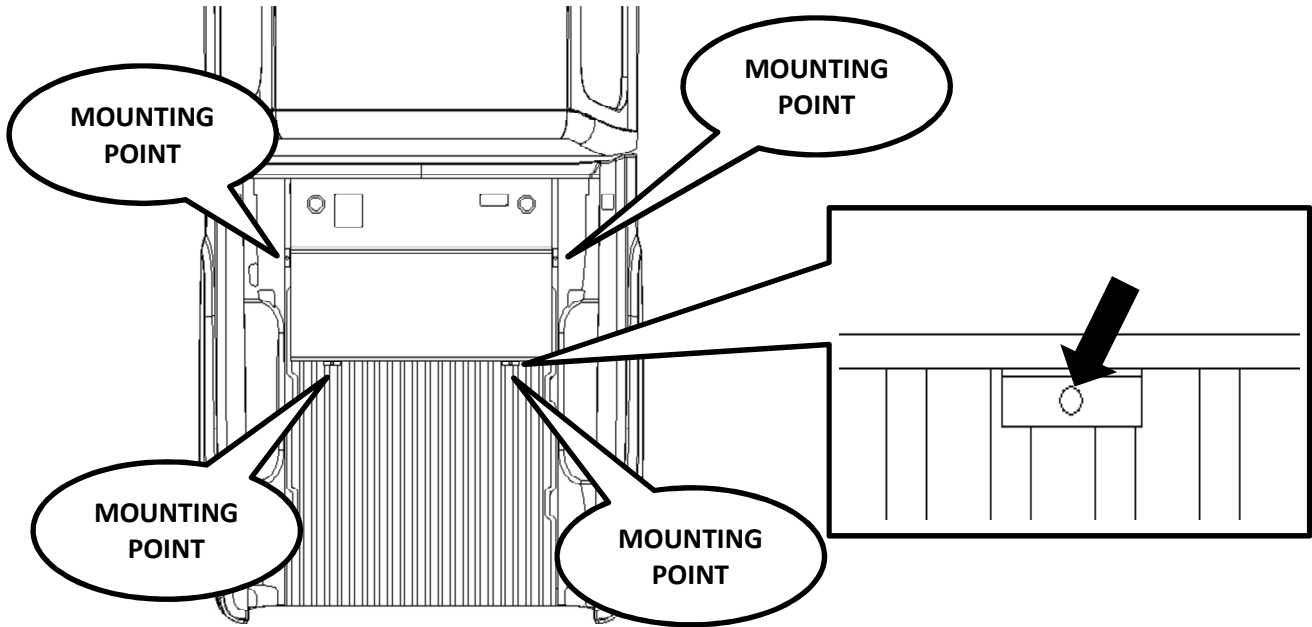

**4** Check the underside of the truck bed below the marked locations for clearance. If something is in the way of the marked location, shift the tank to avoid the obstruction.

Remove the tank from the truck bed, and drill a 3/8" hole at each of the marked locations. Check with manufacturer/body shop for recommendations for sealing drilled holes.

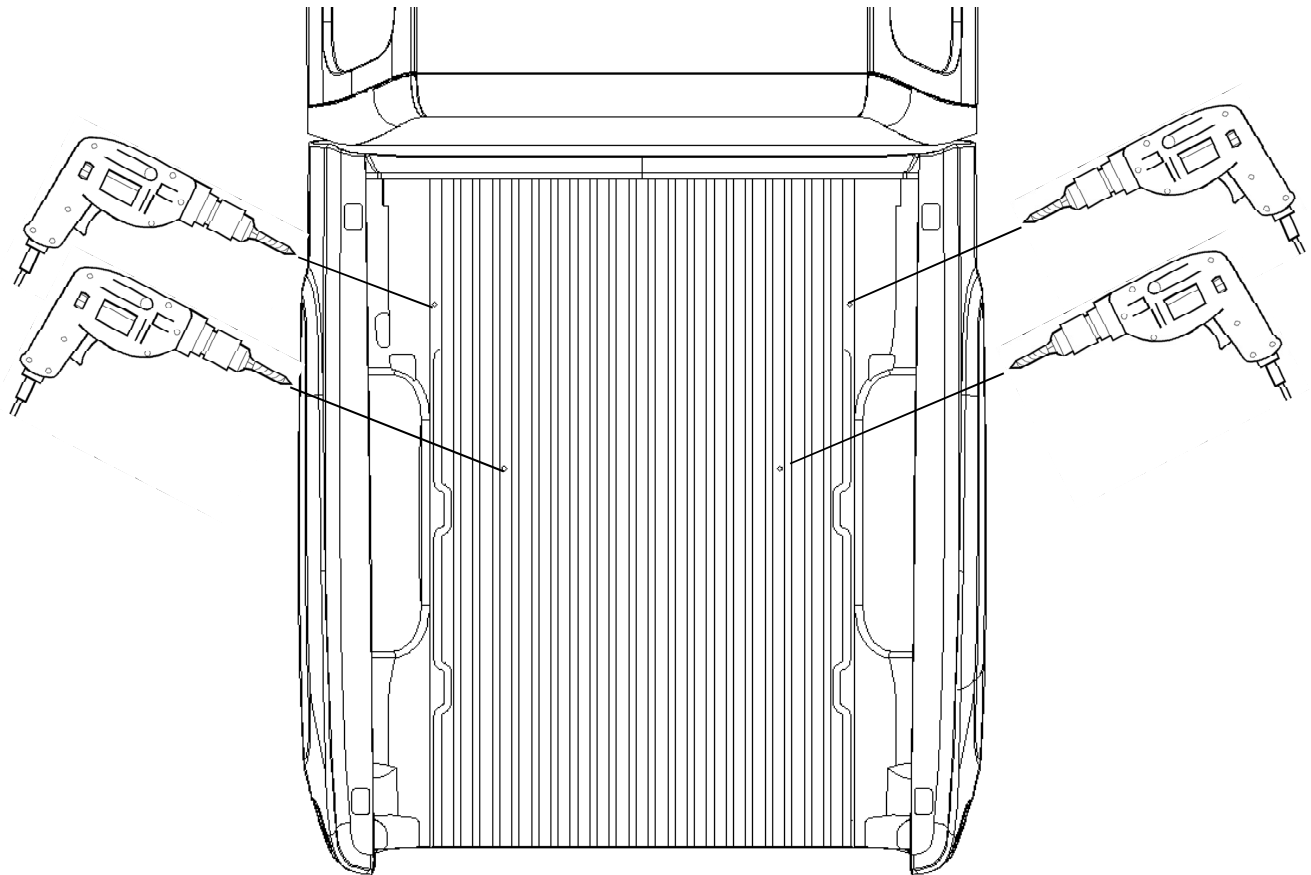

**4**

After drilling the holes, return the tank to the truck bed and align the tank mounting locations with the holes in the truck bed.

Depending on when your tank was made, it may be necessary to drill 3/8" holes through the four tank mounting points also.

At the mounting two locations towards the REAR of the tank only, place a 5/16" bolt [B] and 5/16" washer [C] down through the mounting location hole. From the underside of the truck place a rubber bumper [E], 5/16" washer [C], and 5/16" lock nut [D] onto the bolt.

**DO NOT COMPLETELY TIGHTEN AT THIS TIME.**

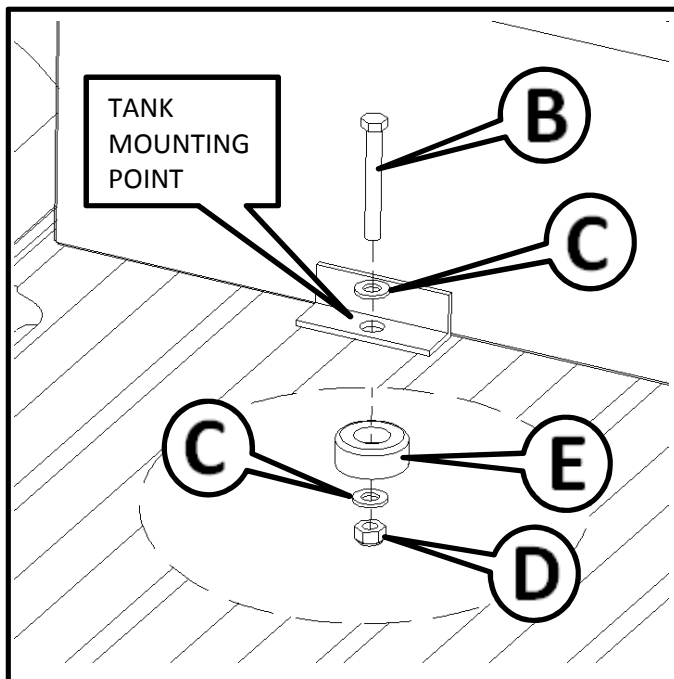

NOTE: The flat side of the rubber bumper will be towards the ground.

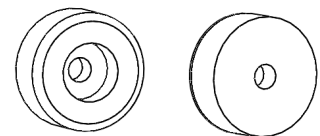

FLAT SIDE

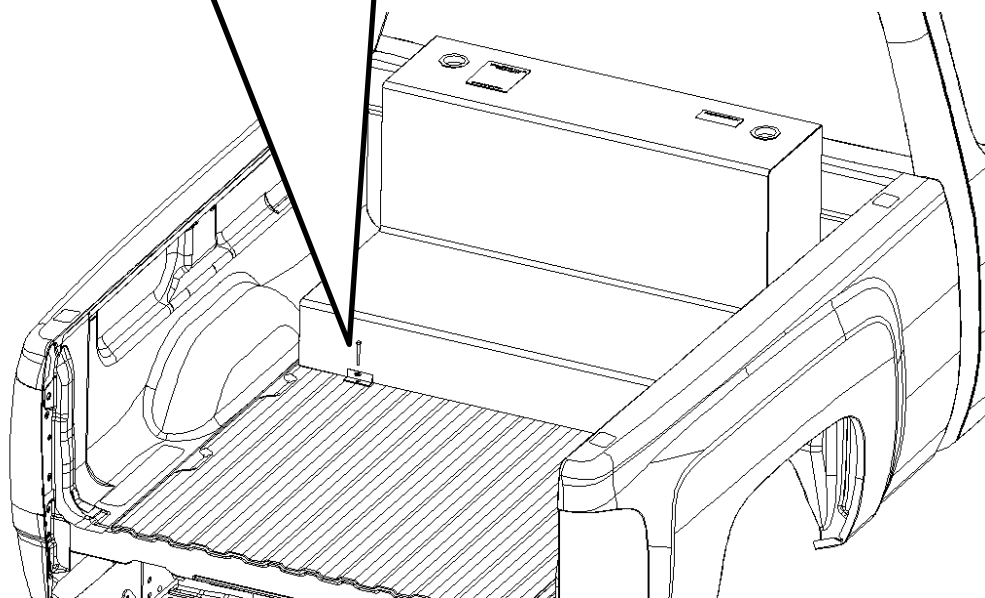

- 5** Replace the chest box on to the tank and align the slot in the brace with the hole in the mounting points on the sides of the tank.

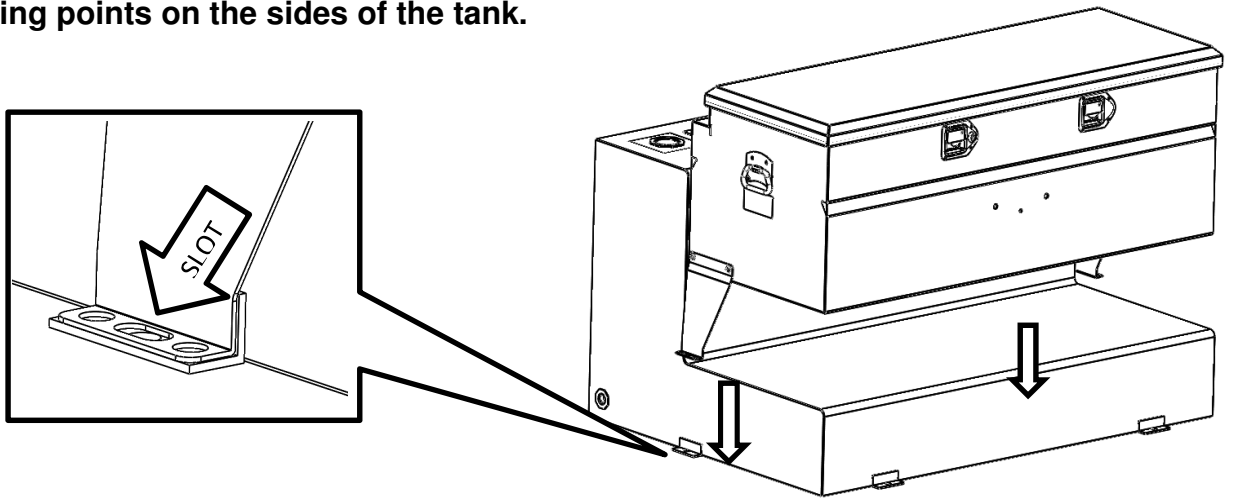

At the side mounting locations, place a 5/16" bolt [B] and 5/16" washer [C] down through the mounting location hole. From the underside of the truck place a rubber bumper [E], 5/16" washer [C], and 5/16" lock nut [D] onto the bolt.

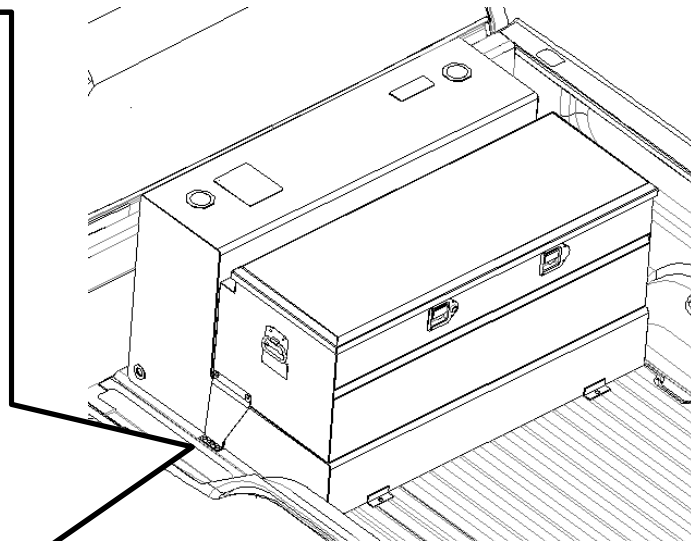
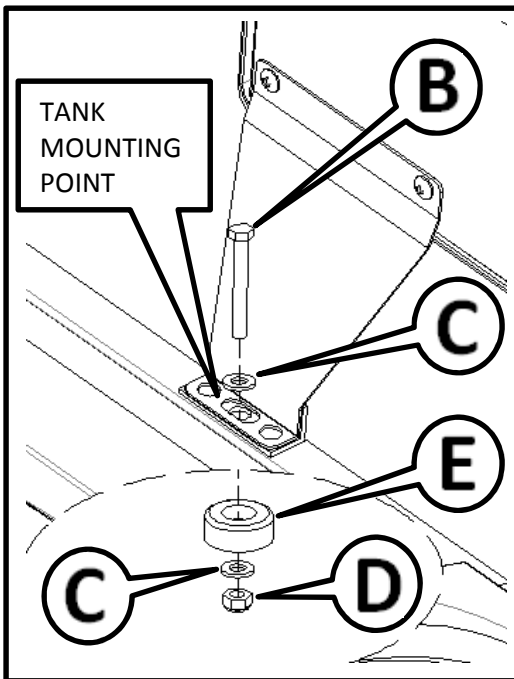

NOTE: The flat side of the rubber bumper will be towards the ground.

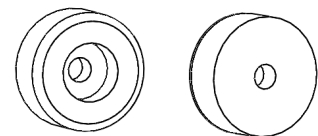

Repeat on the passenger side.

**FOR ALL FOUR MOUNTING LOCATIONS:**

Tighten the nut and bolt using a 1/2" socket and wrench until the rubber bumper comes into contact with the underside of the truck bed. Grab the rubber bumper and try to rotate it around the bolt. If the rubber bumper can still rotate on the bolt, continue to tighten the nut until the rubber bumper can no longer be turned by hand. Once the rubber bumper can no longer be turned by hand, tighten the nut one additional 360 degree turn.



## DEE ZEE, INC. WARRANTY AGREEMENT

Dee Zee, Inc. guarantees the original purchaser a limited lifetime warranty against manufacturer defects in materials, workmanship, and design under normal use, excluding damage resulting from road hazards such as gravel or other debris, product misuse, improper installation, impairments from accidents, product modifications, improper repairs, spills, vandalism, product neglect, or acts of God.

This warranty applies only to the original purchaser of new product(s) and is limited to the replacement of genuine Dee Zee products. Modification of any kind to Dee Zee products voids all warranty coverage. Warranty does not include electrical components, installation, cost of removal, labor, transportation costs, loss of use, inconvenience, or consequential damages.

### WARRANTY COVERAGE - MATERIALS & WORKMANSHIP

#### LIMITED LIFETIME WARRANTY:

- STAINLESS STEEL: Side Steps, Grill Guards, Bull Bars, Bed Caps, and Side Rails
- ALUMINUM: Side Steps, Running Boards, Storage Boxes, Transfer Tanks, Bed Protection, Invis-A-Racks, and Cab Racks
- PLASTIC: Storage Boxes and Bed Caps

#### THREE-YEAR WARRANTY:

- POWDER-COATED / E-COATED STEEL: Side Steps, Running Boards, Storage Boxes, Transfer Tanks, Cab Racks, Ladder Racks, and Cargo Carriers
- OTHER: Tailgate Assist, Bed Mats, Floor Mats, and Auxiliary Fuel Connection Kits
- All Products Not Otherwise Listed Individually

### WARRANTY COVERAGE – FINISH PROTECTION

The finish of all Dee Zee products is covered for one-year (1) from the date of purchase. Dee Zee products have a high quality finish that must be cared for and maintained like any other exposed finish on the vehicle. Protect the finish with non-abrasive automotive wax (e.g. Pure Carnuba) on a regular basis. Applying soaps, polishes, or waxes that contain an abrasive compound may scratch the finish and leave the exposed material susceptible to corrosion.

## **WARRANTY COVERAGE – COMPONENT PARTS**

Operational items such as shocks, latches, hinges, and wear items including, but not limited to, mud flaps, step pads, end caps, hardware, seals, etc. have a one-year (1) warranty. Replacement component parts can be ordered via credit card (MasterCard or VISA) by calling 1-800-779-2102. All replacement parts are non-returnable and non-refundable.

### **GPI® TRANSFER TANK PUMPS & ACCESSORIES:**

All Great Plains Industries (GPI) products, including transfer tank pumps and fuel meters are covered by GPI's warranty policies. Dee Zee's warranty terms do not apply to GPI products. To submit a warranty claim, please contact GPI at 1-800-835-0113 or visit [www.gpi.net](http://www.gpi.net).

## **WARRANTY SUBMISSION PROCEDURE**

All warranty claims will be initiated at the place of purchase. The original purchaser will be required to present the original sales receipt with purchase date shown and provide photographs of the defect.

In the event the originally purchased product style is no longer available, Dee Zee will warranty the defective part with a current equivalent. If a comparable product is no longer available, the product would be returned to the store of purchase for a refund or the applicable cost difference can be paid to choose an alternate style.

## **DISCLAIMER**

Buyer assumes all risk, liability, and cost for the installation and use of Dee Zee products. All products are sold as appearance accessories and should not be relied upon as protection for the vehicle or its occupants in the event of an accident. Vehicles equipped with a supplemental restraints system (air bags) deployed by impact and collision avoidance systems should not be modified in any way. Always consult the vehicle manufacturer if you have any questions regarding supplemental restraint systems and sensors. Dee Zee, Inc. assumes no liability for injury, loss, incidental or consequential damages in the event of an accident.